

Product Data Sheet

OUTDOOR LIGHTING

VIGO-PC 1x Max. 18WW

CODE: **3310720**



Area of application

Tri-proof Lighting Fixture to be used with Single-Ended LED Tubes inside.

Suitable for surface-mounting indoor/outdoor lighting applications on Ceilings of Corridors/Rooms in Warehouses, Parking Lots and Industrial Places..

Product Advantages

VIGO PC is a family of single & double triproof light fittings, IP65, surface or suspended mounted. Ready to operate with single ended LED tubes (60/120/150cm), T8 G13 base. (tubes are not included). Body made of ABS. UV stabilized polycarbonate diffuser. Two galvanized steel clamps for surface mounting of the luminaire. Two fibreglass nylon cable glands. Reflector of steel sheet, electrostatically painted in white. Equiped with stainless steel fixing clamps.

Product Data Sheet

OUTDOOR LIGHTING

VIGO-PC 1x Max. 18WW

CODE: 3310720

Product Features

Electrical

Power: 1x Max. 18WWatt

Voltage:

Power Factor: --

Electrical Protection: Class I

Surge Protection: --

Dimmability: --

Switch Cycle: --

Material Characteristics

IP Class: IP65

IK Class: -

Material: ABS

Ambient Temperature: $-15 < t_a < +55$

Body Color:

Product Size:

Lighting

Lumen: --

Luminaire efficacy: --

Colour Temperature: --

Beam Angle: --

CRI : Ra --

Lifetime: --

EEL : --

Packing Informations

Pieces/Outbox: 8

Outbox Size: 1290x300x265 mm

Outbox G.W.: 13,84 Kg

Outbox Volume: 0,1026 m³

Unit Weight: 1730 gr

Barcode : 6972538047380

Technical Drawing

Light Distribution Curve

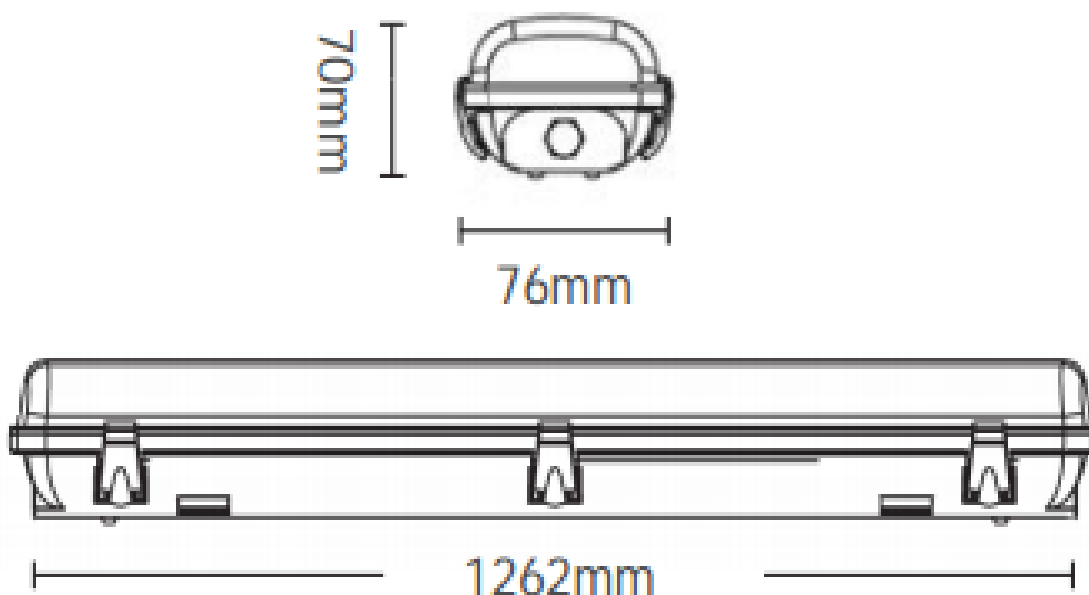

VITO EUROPE

102 Iztochna Tangenta str. 4th Floor

P.C. 1528, Sofia/Bulgaria

Phone: +359 2 4341575

E-mail: info@vitoeurope.com

www.vitolighting.com